

ZCC1100H

CRAWLER CRANE



Zoomlion Heavy Industry Science & Technology Co.,Ltd.

Add: Zoomlion Overseas Building, No.613, 3rd Section, Furong Middle Road, Yuhua District, Changsha, Hunan, P.R.China 410205



Printed in China, VN-EN-MC-2016-01

Copyright © 2016 Zoomlion. All rights reserved. Reproduction and copying of any part of the contents is not allowed for any purposes without Zoomlion's written approval. Note: No product coating appearance shall be subject to sample.

en.zoomlion.com

Crawler Crane

ZCC1100H crawler crane, whose maximum lifting capacity is 100t, is born to satisfy the demands from first-class international market. With advanced technology and excellent performance, the product serves the end-users of the mature market. The engineers summarize rules and experience from the user's construction data, thus making the product powerful enough, practical, and friendly to use.

Environmental

- Its emission satisfies U.S. EPA Tier 3 standard.
- Free-fall winch brake is environmental friendly wet multi-disc friction brake.
- Self-assembly and dismantling mode is set so that the crane can assemble and dismantle the crawler carriers and boom sections without the help of an auxiliary crane, reducing energy consumption.

Intelligent

- Limit load control strategy makes all simultaneous movements realized, and ensures that no impact is generated to the system when adding or reducing the number of simultaneous movements in light or medium load condition.
- Free-fall winch control scheme. It studies the influence of the load on the boom head during brake with a load, optimizes the relationship between the brake force and impact force, and prevent casualty and property loss due to wrong operation.
- Ground pressure precalculation system. Precalculate the ground pressure, thus providing proof for the user to deal with the ground matters.

ZCC1100H

Reliable

- The key components have undergone tens of thousands of reliability tests before delivery.
- The crane operations can be performed stably with high efficiency.
- The visual alarm is fitted to ensure safe crane operation. If required construction conditions can not be met, the system will sent out alarms.



Main Specifications

Item	Value
Max. lifting capacity / radius	100/3.2 t/m
Max. lifting capacity of fixed jib	8 t
Main boom length	13~67 m
Fixed jib length	6~18 m
Max. length of main boom with fixed jib	55+18 m
Main boom angle	30~82.5°
Fixed jib angle	10°, 30°
Traveling speed (high/low speed)	1.25/0.5 km/h
Gradeability	30% (16.7°)
Max. transport weight of basic machine	45.3 t
Deadweight of crane with basic boom	86 t
Counterweight	28 t (Rear counterweight)
	10 t (Central counterweight)

Overall View

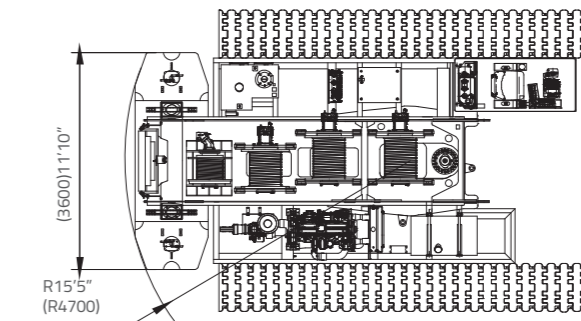
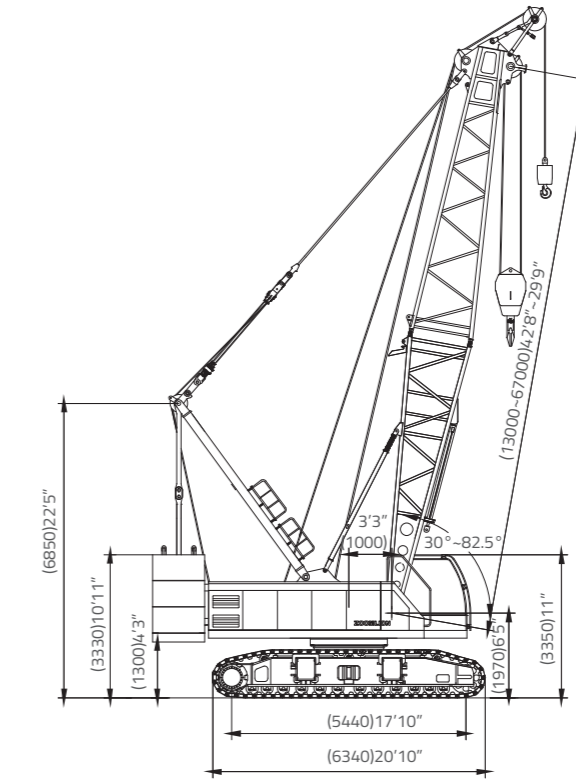

Lifting Height On S-1 Boom

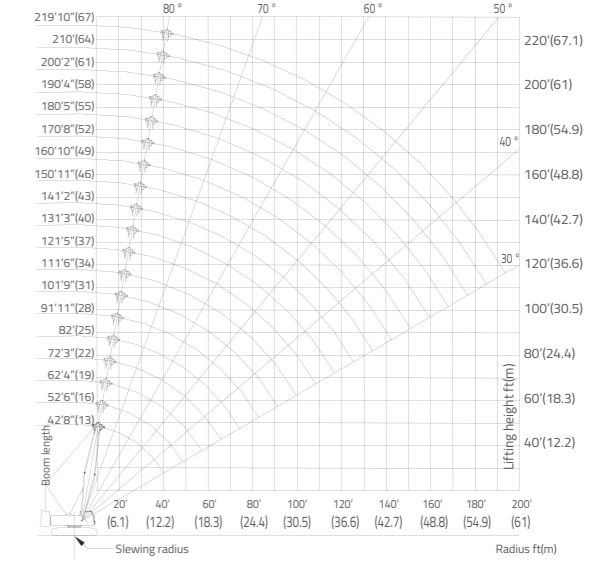

Note: The deflection of boom is not taken into consideration

